

IM3220 a High-Efficiency Protocol Controller for IEEE1588

Applications

- Timing and Synchronization
- Telecom Network clients
- Industrial Automation
- Robotics
- Power Transmission
- Test and Measurement
- Sensor Networks



The IM3220 represents a new type of platform components from Imsys. It combines the best features of traditional CISC architectures and efficient use of resources with FPGA flexibility for a pre-defined application – time synchronization. It dramatically reduces the cost and size of precision time synchronization hardware using the IEEE 1588 protocol. The outstanding features IM3220 stem from the ability to analyze and act on gate level in real-time.

A processor architecture optimized on memory interaction without cache results in high energy efficiency and performance. With its ability to sustain almost 20 Mbit/s of IP dataflow while running the IEEE 1588 Protocol Engine software and consuming less than 42 mW the IM3220 offers the best performance/energy ratio in the industry.

The IM3220 integrated circuit comes with a complete software platform including real-time operating system, flash file system, TCP/IP communication stack, FTP and web server. For the execution of the IEEE 1588 protocol, a version 1 stack with a full ordinary clock implementation from Zurich University of Applied Sciences is included in the IM3220. The software platform comes integrated and tested as a firmware profile for time stamping applications.

Features

- Deterministic Real-Time Operating System and power fail-safe file system
- Supports C and Assembler programming
- Advanced source level debugging and profiling
- Accelerated IEEE 754 Floating Point arithmetic, single and double precision
- The arithmetic core contains both ALU and Multiplier-Accumulator (8x8 and 32 bits, respectively)
- Dual channel 10/100Mbit/s Ethernet MAC
- Three UARTs, one I²C/SPI serial interface
- Eight DMA channels with 83 MB/s sustained total data rate
- Precise Timestamp Engine with IEEE 1588 support
- API programmable IEEE 1588 version 1 software stack included
- Up to 18.5 Mbit/s sustained UDP throughput with 1 Hz synch rate
- Hardware communication channel supporting synchronization frame rates up to 256 Hz
- Software controlled PLL, Multiple power saving modes
- Available as reference module with on-board memories and PSU.



IEEE 1588 timestamp support

The IM3220 can discipline its PTP clock by controlling an external oscillator using an analog control signal or a digital serial interface. As a lower-cost

alternative it can use

its on-chip oscillator, with only a crystal externally. The local precise time can be used both by software and directly by external hardware through the GPIO ports. The time presentation to the external is very precise, since it has no jitter caused by instruction execution.

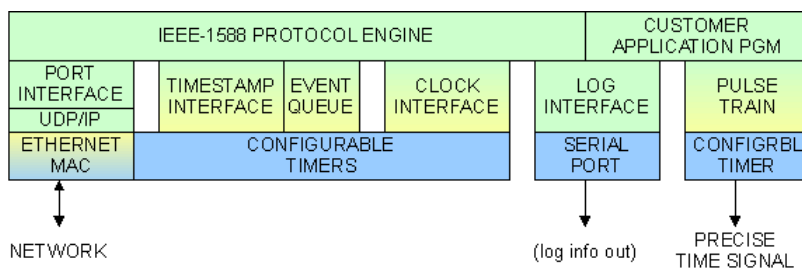

Block Diagram

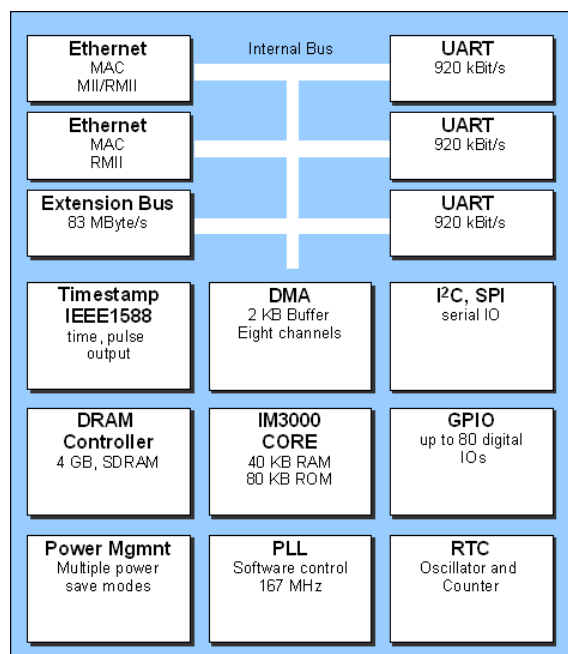

The diagram shows the main parts of the processor. The ROM and RAM of the IM3000 core contain microcode. This enables acceleration of CPU intensive tasks with orders of magnitude. By coding functions like Ethernet MAC, timestamp unit, interrupt controller etc, the processor can handle tasks not seen in comparable products.

Using the flexible extension bus new peripherals or interfaces in e.g. an FPGA or CPLD can extend the on-chip functions.

Technical Specifications

- Supply Voltage 3.0 – 3.6V, optional 1.8V core
- Typical internal power consumption is 42 mW at 1.8V/167 MHz including core, PLL, DMA etc.
- Additional 20 mW is consumed by the SDRAM interface 3.3V/167MHz
- Real-time clock current consumption 5 µA from battery
- Operating temperature range -40 to +85 °C
- 167 MHz max. oscillator frequency
- 80 Input/Output pins with tri-state support
- 12x12 mm BGA, 180 connections (14x14 grid, 0.8 mm pitch).



Imsys may make changes to specifications and product descriptions at any time, without notice.