



IM3221

The Connected Embedded Controller with IEEE1588 Synchronization and Java

Applications

- Timing and Synchronization
- Telecom Network clients
- Industrial Automation
- Robotics
- Power Transmission
- Test and Measurement
- Sensor Networks
- Java Enabled Products



IM3221 represents a new range of microcontrollers from Imsys Technologies. The device combines the broad capability of traditional CISC architectures with the efficient use of resources that dedicated RISC machines provides. Imsys' controllers deliver an outstanding cost/performance ratio for embedded applications where footprint and one-service-all requirements dominate.

The IM3221 is a dedicated controller for time synchronized applications. Its outstanding features stem from the ability to analyze and act on gate level, in real-time. With its ability to sustain almost 20 Mbit/s of IP dataflow, while running the IEEE1588 Protocol software in the background, and consuming less than 42 mW the controller offers the best performance/energy ratio in the industry. IM3221 dramatically reduces the cost and size of time synchronization.

IM3221 embeds a complete software platform including real-time operating system, flash file system, TCP/IP communication stack, FTP and web server. The device is enabled with Java and the application designer can mix and match between Java, C and assembler languages to optimize performance. For the execution of IEEE1588 protocol version 1, a software stack with full ordinary clock implementation from Zurich University of Applied Sciences is already integrated. Version 2 of the IEEE1588 protocol will be released for the IM3200 microcontroller series during 2Q 2008.

Features

- Deterministic Real-Time Operating System and power fail-safe file system
- Accelerated IEEE 754 Floating Point arithmetic, single and double precision
- Dual channel 10/100Mbit/s Ethernet MAC
- Three UARTs, one I²C/SPI serial interface
- Eight DMA channels with 83 MB/s sustained total data rate
- Precise Timestamp Engine with IEEE 1588 support
- API programmable IEEE 1588 version 1 software stack included
- Up to 18.5 Mbit/s sustained UDP throughput with 1 Hz synch rate
- Hardware communication channel supporting synchronization frame rates up to 256 Hz.



IEEE 1588 timestamp support

The IM3221 can discipline its PTP clock by controlling an external oscillator using an analog control signal or a digital serial interface. As a lower-cost alternative it can use

its on-chip oscillator, with only a crystal externally. The local precise time can be used both by software and directly by external hardware through the GPIO ports. The time presentation to the external is very precise, since it has no jitter caused by instruction execution.

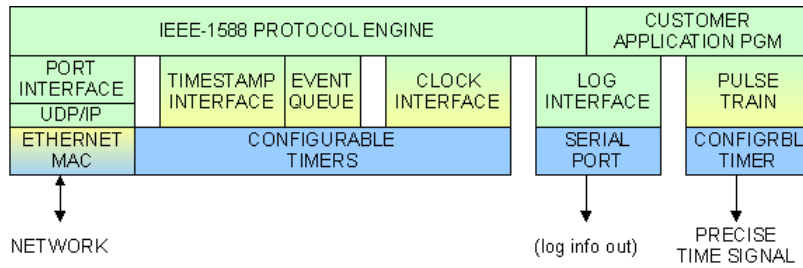

Block Diagram

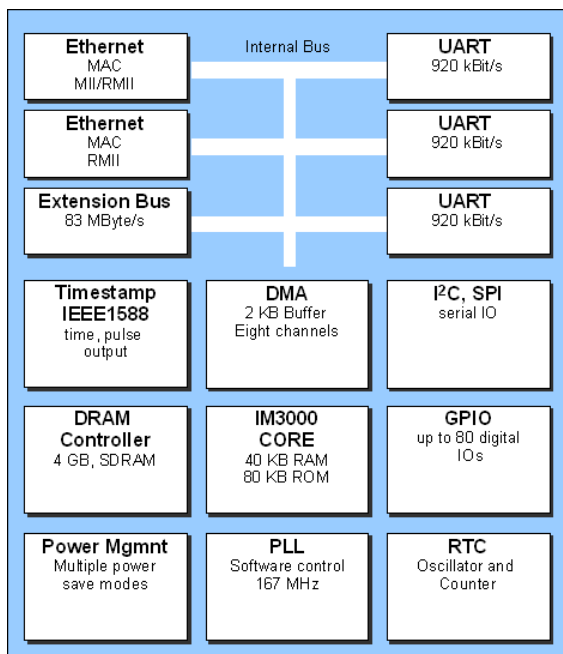

The diagram shows the main parts of the processor. The ROM and RAM of the IM3000 core contain microcode. This enables acceleration of CPU intensive tasks with orders of magnitude. By coding functions like Ethernet MAC, timestamp unit, interrupt controller etc, the processor can handle tasks not seen in comparable products.

Using the flexible extension bus new peripherals or interfaces in e.g. an FPGA or CPLD can extend the on-chip functions.

Technical Specifications

- Supply Voltage 3.0 – 3.6V, optional 1.8V core
- Typical internal power consumption is 42 mW at 1.8V/167 MHz including core, PLL, DMA etc.
- Additional 20 mW is consumed by the SDRAM interface 3.3V/167MHz
- Real-time clock current consumption 5 µA from battery
- Operating temperature range -40 to +85 °C
- 167 MHz max. oscillator frequency
- 80 Input/Output pins with tri-state support
- 12x12 mm BGA, 180 connections (14x14 grid, 0.8 mm pitch).

Imsys may make changes to specifications and product descriptions at any time, without notice.

Imsys Technologies

Imsys Technologies AB, Sweden
 Johanneslundsvägen 3
 SE-194 61 Upplands Väsby
 Sweden
 +46 8 594 110 70 phone
 +46 8 591 110 89 fax

Imsys Technologies, USA
 9903 North Poetry Ln
 Terrell, TX 75160
 USA
 877 775 1627

838 Henderson Ave
 Sunnyvale, CA 94086
 USA

Email:
info@imsystech.com
 Web:
www.imsystech.com